

SPECIFICATIONS
 Current Rating: 2A AC,DC
 Voltage Rating: 250V AC,DC
 Temperature Range: -25°C ~ +85°C
 Contact Resistance: 30mΩ Max.
 Insulation Resistance: 1000MΩ Min.
 Withstanding Voltage: 800V AC/minute
 Material: Nylon 66,UL94V-0
 Color: Black

Ordering Information & Dimensions

PART NO.	Dimensions	
	A	B
A2211H-2X02P	2.00	6.00
A2211H-2X03P	4.00	8.00
A2211H-2X04P	6.00	10.00
A2211H-2X05P	8.00	12.00
A2211H-2X06P	10.00	14.00
A2211H-2X07P	12.00	16.00
A2211H-2X08P	14.00	18.00
A2211H-2X09P	16.00	20.00
A2211H-2X10P	18.00	22.00
A2211H-2X11P	20.00	24.00
A2211H-2X12P	22.00	26.00
A2211H-2X13P	24.00	28.00
A2211H-2X14P	26.00	30.00
A2211H-2X15P	28.00	32.00
A2211H-2X16P	30.00	34.00
A2211H-2X17P	32.00	36.00
A2211H-2X18P	34.00	38.00
A2211H-2X19P	36.00	40.00
A2211H-2X20P	38.00	42.00

				广瑞电子科技有限公司		TITLE : 2.00mm PITCH HOUSING	
		UNIT	SCALE	SHEET			
		mm		1 of 1			
		DRAWN BY SUSAN		APPROVED BY HENLY			
B3	REVISE	2008.01.14	2001.02.01	2001.02.01			
B2	REVISE	2007.02.01	GENERAL TOLERANCE				
B1	REVISE	2006.03.27	X X ±0.25	ANGLE ±			
B0	NEW RELEASE	2005.12.05	X XX ±0.15				
REV.	DESCRIPTION	DATE	X XXX ±0.05		DRAW NO. : A2211H-2XNP		
						REV.	B3

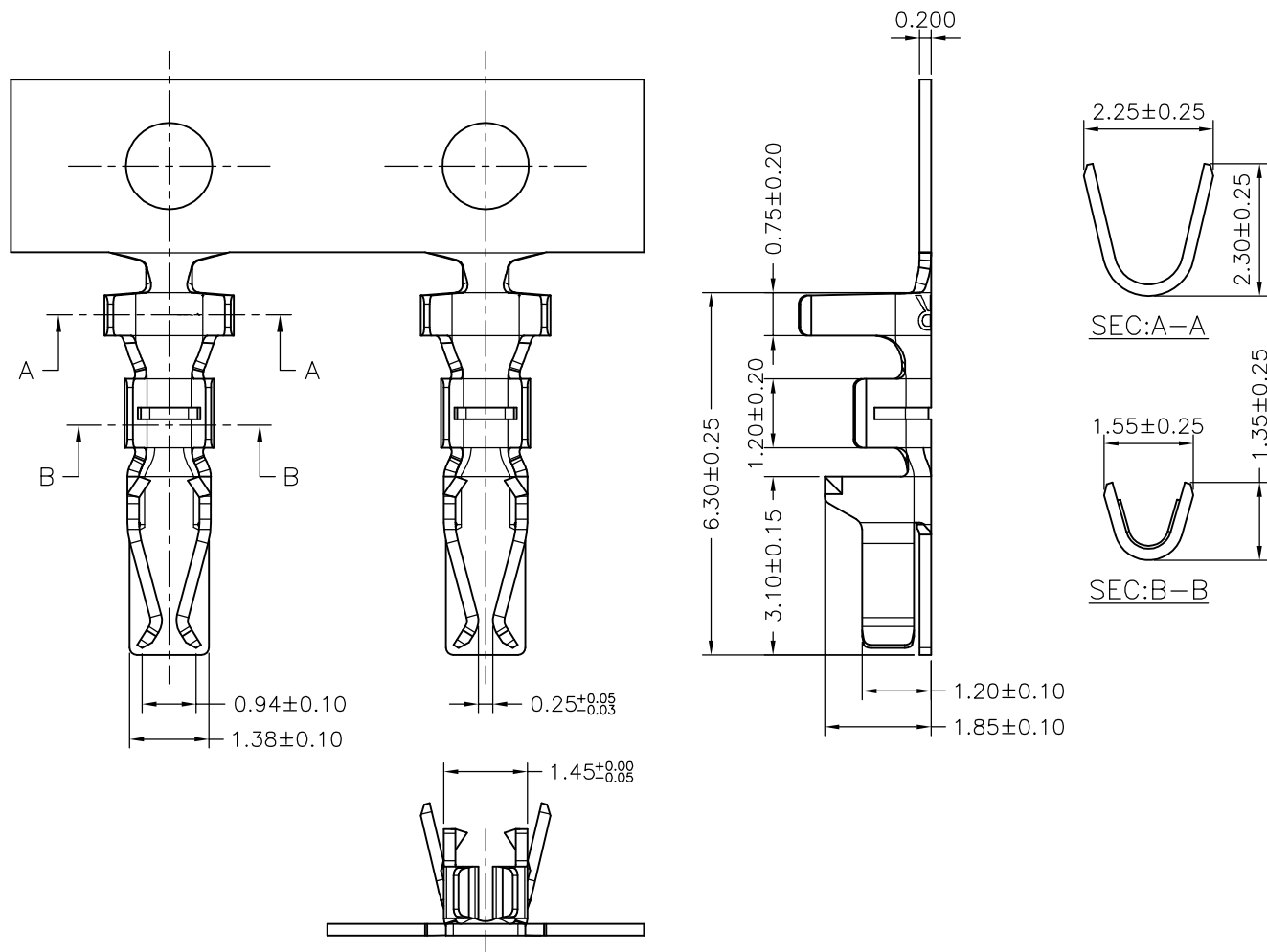

Ordering Information & Specifications

Part No.	Wire Range	Insulation O.D.	Material	Finish	Qty/reel
A2211-TPE	AWG#22-#30	1.45mm(max)	Phosphor Bronze	Tin-plated	10,000pcs

Note:E-Stamping before Tin-plated

						广瑞电子科技有限公司				
						UNIT	SCALE	SHEET	TITLE :	
						mm		1 of 1		
						DRAWN BY		APPROVED BY		2.00mm PITCH CRIMP TERMINAL
						SUSAN		HENLY		
						2001.02.01		2001.02.01		
						GENERAL TOLERANCE				
B2	REVISE	2007.03.16				ANGLE ±		DRAW NO. : A2211-XX		REV. B2
B1	REVISE	2007.02.01			X X ± 0.25					
B0	NEW RELEASE	2005.12.05			X XX ± 0.15					
REV.	DESCRIPTION	DATE			X XXX ± 0.05					

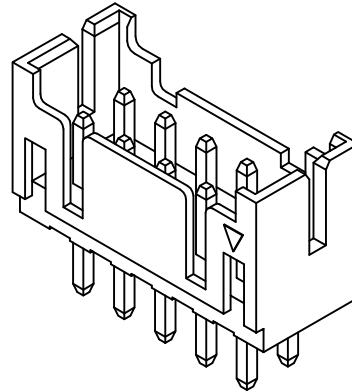

SPECIFICATIONS
 Current Rating: 2A AC,DC
 Voltage Rating: 250V AC,DC
 Temperature Range: -25°C ~ +85°C
 Contact Resistance: 30mΩ Max.
 Insulation Resistance: 1000MΩ Min.
 Withstanding Voltage: 800V AC/minute
 Pin Material: Brass/Tin-plated
 Material: Nylon 66,UL94V-0
 Color: Black

Ordering Information & Dimensions

PART NO.	Dimensions	
	A	B
A2211WV-2X02P	2.00	6.00
A2211WV-2X03P	4.00	8.00
A2211WV-2X04P	6.00	10.00
A2211WV-2X05P	8.00	12.00
A2211WV-2X06P	10.00	14.00
A2211WV-2X07P	12.00	16.00
A2211WV-2X08P	14.00	18.00
A2211WV-2X09P	16.00	20.00
A2211WV-2X10P	18.00	22.00
A2211WV-2X11P	20.00	24.00
A2211WV-2X12P	22.00	26.00
A2211WV-2X13P	24.00	28.00
A2211WV-2X14P	26.00	30.00
A2211WV-2X15P	28.00	32.00
A2211WV-2X16P	30.00	34.00
A2211WV-2X17P	32.00	36.00
A2211WV-2X18P	34.00	38.00
A2211WV-2X19P	36.00	40.00
A2211WV-2X20P	38.00	42.00

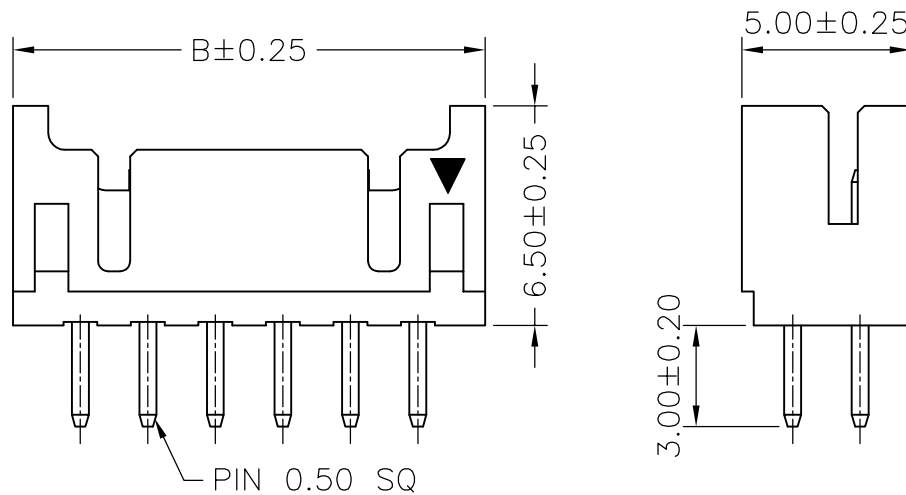
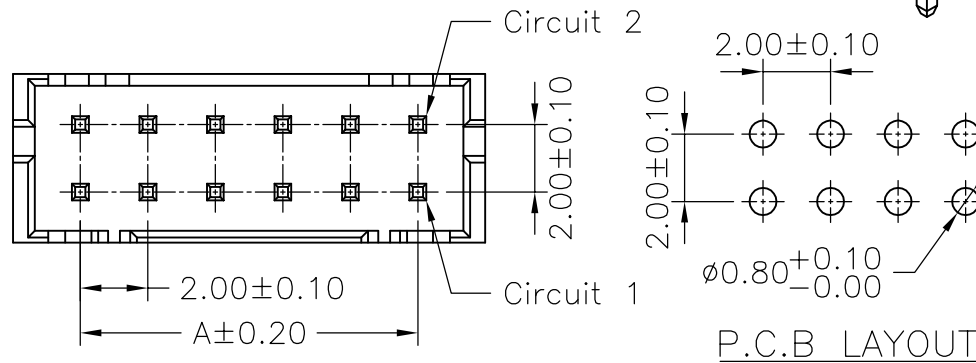

广瑞电子科技有限公司			
UNIT	SCALE	SHEET	TITLE:
mm		1 of 1	2.00mm PITCH 180° WAFER
DRAWN BY SUSAN 2001.02.01		APPROVED BY HENLY 2001.02.01	
GENERAL TOLERANCE			
B1	REVISE	2007.02.27	X. X±0.25
B0	NEW RELEASE	2005.12.05	X. XX±0.15
REV.	DESCRIPTION	DATE	X. XXX±0.05
DRAW NO.:			REV.
A2211WV-2XNP			B1

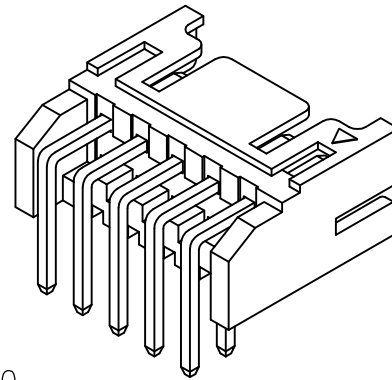

SPECIFICATIONS
 Current Rating: 2A AC,DC
 Voltage Rating: 250V AC,DC
 Temperature Range: -25°C ~ +85°C
 Contact Resistance: 30mΩ Max.
 Insulation Resistance: 1000MΩ Min.
 Withstanding Voltage: 800V AC/minute
 Pin Material: Brass/Tin-plated
 Material: Nylon 66,UL94V-0
 Color: Black

Ordering Information & Dimensions

PART NO.	Dimensions	
	A	B
A2211WR-2X02P	2.00	6.00
A2211WR-2X03P	4.00	8.00
A2211WR-2X04P	6.00	10.00
A2211WR-2X05P	8.00	12.00
A2211WR-2X06P	10.00	14.00
A2211WR-2X07P	12.00	16.00
A2211WR-2X08P	14.00	18.00
A2211WR-2X09P	16.00	20.00
A2211WR-2X10P	18.00	22.00
A2211WR-2X11P	20.00	24.00
A2211WR-2X12P	22.00	26.00
A2211WR-2X13P	24.00	28.00
A2211WR-2X14P	26.00	30.00
A2211WR-2X15P	28.00	32.00
A2211WR-2X16P	30.00	34.00
A2211WR-2X17P	32.00	36.00
A2211WR-2X18P	34.00	38.00
A2211WR-2X19P	36.00	40.00
A2211WR-2X20P	38.00	42.00

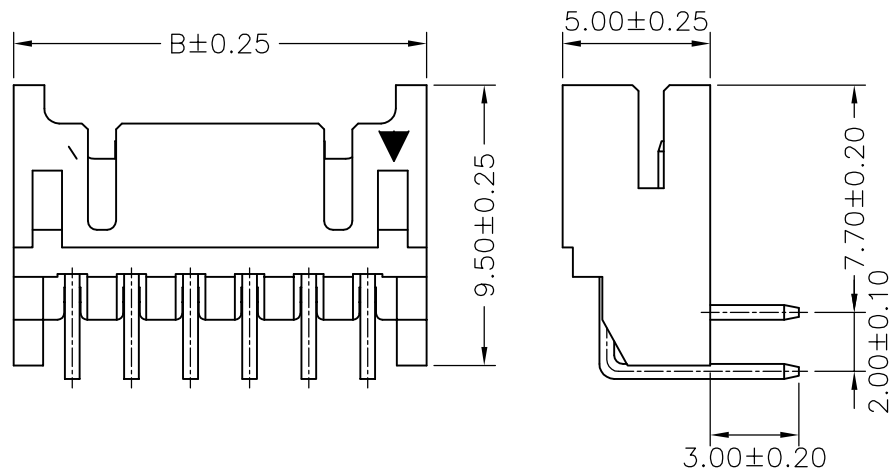
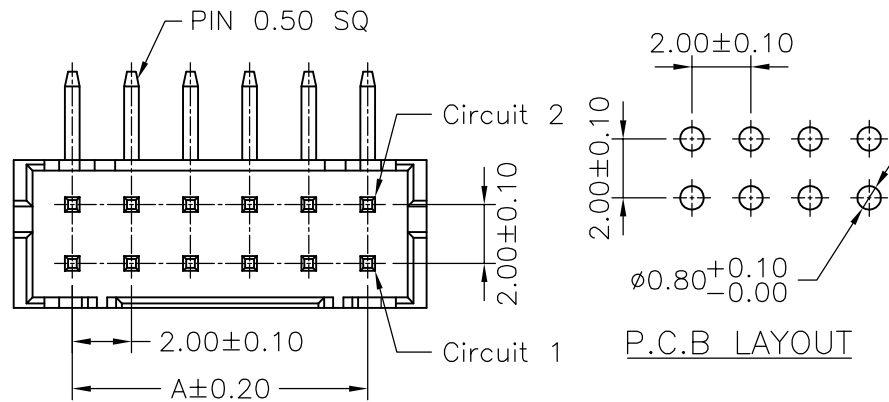

广瑞电子科技有限公司			
UNIT	SCALE	SHEET	TITLE:
mm		1 of 1	2.00mm PITCH 90° WAFER
DRAWN BY SUSAN 2001.02.01		APPROVED BY HENLY 2001.02.01	
GENERAL TOLERANCE			
B1	REVISE	2007.02.27	X. X±0.25
B0	NEW RELEASE	2005.12.05	X. XX±0.15
REV.	DESCRIPTION	DATE	X. XXX±0.05
			ANGLE±
			DRAW NO.:
			A2211WR-2XNP
			REV. B1

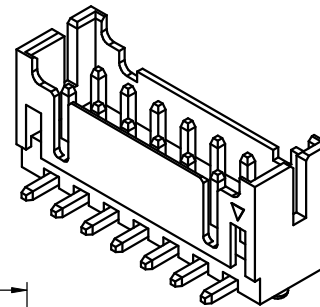
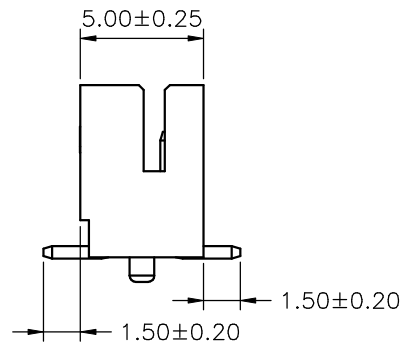
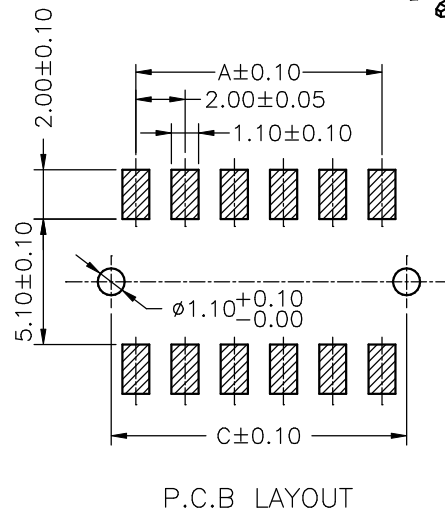
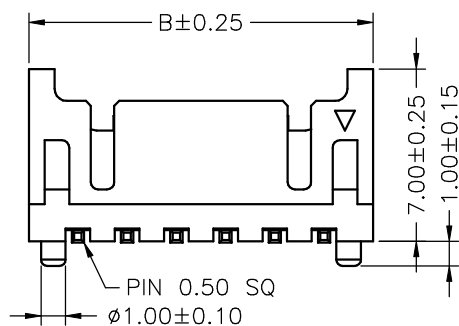
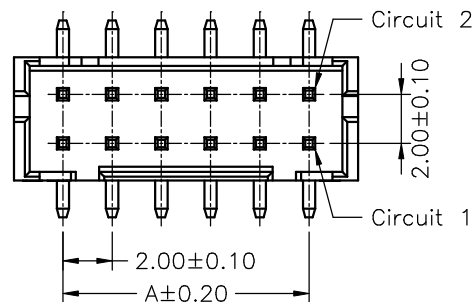
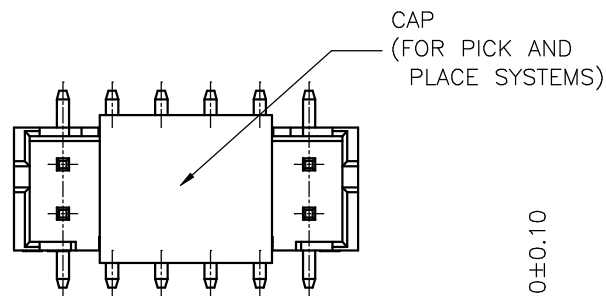

SPECIFICATIONS

Current Rating: 2A AC,DC
 Voltage Rating: 250V AC,DC
 Temperature Range: -25°C ~ +85°C
 Contact Resistance: 30mΩ Max.
 Insulation Resistance: 1000MΩ Min.
 Withstanding Voltage: 800V AC/minute
 Pin Material: Brass/Gold-flash
 Material: Nylon 6T,UL94V-0
 Cap: Nylon 6T,UL94V-0,Natural(Beige)
 Color: Natural(Beige)

Ordering Information & Dimensions

PART NO.	Dimensions		
	A	B	C
A2211WA-SF-2X2P	2.00	6.00	4.00
A2211WA-SF-2X3P	4.00	8.00	6.00
A2211WA-SF-2X4P	6.00	10.00	8.00
A2211WA-SF-2X5P	8.00	12.00	10.00
A2211WA-SF-2X6P	10.00	14.00	12.00
A2211WA-SF-2X7P	12.00	16.00	14.00
A2211WA-SF-2X8P	14.00	18.00	16.00
A2211WA-SF-2X9P	16.00	20.00	18.00
A2211WA-SF-2X10P	18.00	22.00	20.00
A2211WA-SF-2X11P	20.00	24.00	22.00
A2211WA-SF-2X12P	22.00	26.00	24.00
A2211WA-SF-2X13P	24.00	28.00	26.00
A2211WA-SF-2X14P	26.00	30.00	28.00
A2211WA-SF-2X15P	28.00	32.00	30.00
A2211WA-SF-2X16P	30.00	34.00	32.00
A2211WA-SF-2X17P	32.00	36.00	34.00
A2211WA-SF-2X18P	34.00	38.00	36.00
A2211WA-SF-2X19P	36.00	40.00	38.00
A2211WA-SF-2X20P	38.00	42.00	40.00

广瑞电子科技有限公司

UNIT: mm SCALE: 1 of 2 SHEET: 1 of 2

DRAWN BY: SUSAN 2005.11.04
 APPROVED BY: HENLY 2005.11.04

GENERAL TOLERANCE

B1	REVISE	2006.03.27	X.X±0.25	ANGLE±
B0	NEW RELEASE	2005.12.05	X.XX±0.15	
REV.	DESCRIPTION	DATE	X.XXX±0.05	

2.00mm PITCH
 180° WAFER - SMT TYPE

DRAW NO.: A2211WA-SF-2XNP

REV. B1